

SECTION **IP**
INSTRUMENT PANEL

A
B
C
D
E
F
G
H
I
IP
K
L
M
N
O
P

CONTENTS

SYMPTOM DIAGNOSIS	2	PREPARATION	10
SQUEAK AND RATTLE TROUBLE DIAG- NOSES	2	PREPARATION	10
Work Flow	2	Special Service Tools	10
Inspection Procedure	4	Commercial Service Tools	10
Diagnostic Worksheet	6	REMOVAL AND INSTALLATION	11
PRECAUTION	8	INSTRUMENT PANEL ASSEMBLY	11
PRECAUTIONS	8	Exploded View	11
Precaution for Supplemental Restraint System (SRS) "AIR BAG" and "SEAT BELT PRE-TEN- SIONER"	8	Removal and Installation	12
Precaution Necessary for Steering Wheel Rota- tion after Battery Disconnect	8	CENTER CONSOLE ASSEMBLY	23
Precaution for Battery Service	9	Exploded View	23
Precaution	9	Removal and Installation	24
		Disassembly and Assembly	27

SQUEAK AND RATTLE TROUBLE DIAGNOSES

< SYMPTOM DIAGNOSIS >

SYMPTOM DIAGNOSIS

SQUEAK AND RATTLE TROUBLE DIAGNOSES

Work Flow

INFOID:000000004392115

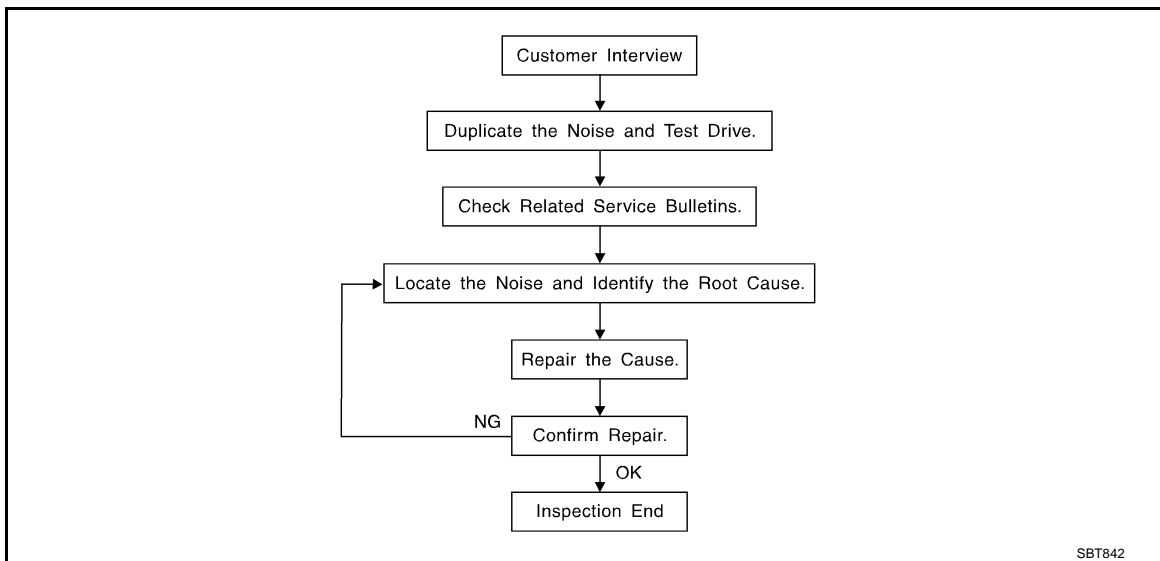

CUSTOMER INTERVIEW

Interview the customer if possible, to determine the conditions that exist when the noise occurs. Use the Diagnostic Worksheet during the interview to document the facts and conditions when the noise occurs and any of customer's comments; refer to [IP-6. "Diagnostic Worksheet"](#). This information is necessary to duplicate the conditions that exist when the noise occurs.

- The customer may not be able to provide a detailed description or the location of the noise. Attempt to obtain all the facts and conditions that exist when the noise occurs (or does not occur).
- If there is more than one noise in the vehicle, perform a diagnosis and repair the noise that the customer is concerned about. This can be accomplished by performing a cruise test on the vehicle with the customer.
- After identifying the type of noise, isolate the noise in terms of its characteristics. The noise characteristics are provided so the customer, service adviser and technician are all speaking the same language when defining the noise.
- Squeak – (Like tennis shoes on a clean floor)
Squeak characteristics include the light contact/fast movement/brought on by road conditions/hard surfaces = higher pitch noise/softer surfaces = lower pitch noises/edge to surface = chirping
- Creak – (Like walking on an old wooden floor)
Creak characteristics include firm contact/slow movement/twisting with a rotational movement/pitch dependent on materials/often brought on by activity.
- Rattle – (Like shaking a baby rattle)
Rattle characteristics include the fast repeated contact/vibration or similar movement/loose parts/missing clip or fastener/incorrect clearance.
- Knock – (Like a knock on a door)
Knock characteristics include hollow sounding/sometimes repeating/often brought on by driver action.
- Tick – (Like a clock second hand)
Tick characteristics include gentle contacting of light materials/loose components/can be caused by driver action or road conditions.
- Thump – (Heavy, muffled knock noise)
Thump characteristics include softer knock/dead sound often brought on by activity.
- Buzz – (Like a bumblebee)
Buzz characteristics include high frequency rattle/firm contact.
- Often the degree of acceptable noise level will vary depending up on the person. A noise that a technician may judge as acceptable may be very irritating to the customer.
- Weather conditions, especially humidity and temperature, may have a great effect on noise level.

DUPLICATE THE NOISE AND TEST DRIVE

SQUEAK AND RATTLE TROUBLE DIAGNOSES

< SYMPTOM DIAGNOSIS >

If possible, drive the vehicle with the customer until the noise is duplicated. Note any additional information on the Diagnostic Worksheet regarding the conditions or location of the noise. This information can be used to duplicate the same conditions when the repair is reconfirmed.

If the noise can be duplicated easily during the test drive, to help identify the source of the noise, try to duplicate the noise with the vehicle stopped by doing one or all of the following:

- 1) Close a door.
 - 2) Tap or push/pull around the area where the noise appears to be coming from.
 - 3) Rev the engine.
 - 4) Use a floor jack to recreate vehicle "twist".
 - 5) At idle, apply engine load (electrical load, half-clutch on M/T models, drive position on A/T models).
 - 6) Raise the vehicle on a hoist and hit a tire with a rubber hammer.
- Drive the vehicle and attempt to duplicate the conditions the customer states exist when the noise occurs.
 - If it is difficult to duplicate the noise, drive the vehicle slowly on an undulating or rough road to stress the vehicle body.

CHECK RELATED SERVICE BULLETINS

After verifying the customer concern or symptom, check ASIST for Technical Service Bulletins (TSBs) related to that concern or symptom.

If a TSB relates to the symptom, follow the procedure to repair the noise.

LOCATE THE NOISE AND IDENTIFY THE ROOT CAUSE

1. Narrow down the noise to a general area. To help pinpoint the source of the noise, use a listening tool (Chassis ear: J-39570, Engine ear and mechanics stethoscope).
2. Narrow down the noise to a more specific area and identify the cause of the noise by:
 - Removing the components in the area that is are suspected to be the cause of the noise.
Do not use too much force when removing clips and fasteners, otherwise clips and fastener can be broken or lost during the repair, resulting in the creation of new noise.
 - Tapping or pushing/pulling the component that is are suspected to be the cause of the noise.
Do not tap or push/pull the component with excessive force, otherwise the noise will be eliminated only temporarily.
 - Feeling for a vibration by hand by touching the component(s) that is are suspected to be the cause of the noise.
 - Placing a piece of paper between components that are suspected to be the cause of the noise.
 - Looking for loose components and contact marks.
Refer to [IP-4, "Inspection Procedure"](#).

REPAIR THE CAUSE

- If the cause is a loose component, tighten the component securely.
- If the cause is insufficient clearance between components:
 - Separate components by repositioning or loosening and retightening the component, if possible.
 - Insulate components with a suitable insulator such as urethane pads, foam blocks, felt cloth tape or urethane tape. A Nissan Squeak and Rattle Kit (J-43980) is available through the authorized Nissan Parts Department.

CAUTION:

Never use excessive force as many components are constructed of plastic and may be damaged.

NOTE:

Always check with the Parts Department for the latest parts information.

The following materials are contained in the Nissan Squeak and Rattle Kit (J-43980). Each item can be ordered separately as needed.

URETHANE PADS [1.5 mm (0.059 in) thick]

Insulates connectors, harness, etc.

- 76268-9E005: 100 × 135 mm (3.937 × 5.315 in)
- 76884-71L01: 60 × 85 mm (2.362 × 3.346 in)
- 76884-71L02: 15 × 25 mm (0.591 × 0.984 in)

INSULATOR (Foam blocks)

Insulates components from contact. Can be used to fill space behind a panel.

- 73982-9E000: 45 mm (1.772 in) thick, 50 × 50 mm (1.969 × 1.969 in)
- 73982-50Y00: 10 mm (0.394 in) thick, 50 × 50 mm (1.969 × 1.969 in)

INSULATOR (Light foam block)

80845-71L00: 30 mm (1.18 in) thick, 30 × 50 mm (1.181 × 1.969in)

FELT CLOTHTAPE

SQUEAK AND RATTLE TROUBLE DIAGNOSES

< SYMPTOM DIAGNOSIS >

Used to insulate where movement does not occur. Ideal for instrument panel applications.

- 68370-4B000: 15 × 25 mm (0.591 × 0.984 in) pad
- 68239-13E00: 5 mm (0.197 in) wide tape roll

The following materials, not found in the kit, can also be used to repair squeaks and rattles.

UHMW (TEFLON) TAPE

Insulates where slight movement is present. Ideal for instrument panel applications.

SILICONE GREASE

Used in place of UHMW tape that is be visible or does not fit. Will only last a few months.

SILICONE SPRAY

Used when grease cannot be applied.

DUCT TAPE

Used to eliminate movement.

CONFIRM THE REPAIR

Confirm that the cause of a noise is repaired by test driving the vehicle. Operate the vehicle under the same conditions as when the noise originally occurred. Refer to the notes on the Diagnostic Worksheet.

Inspection Procedure

INFOID:000000004392116

Refer to Table of Contents for specific component removal and installation information.

INSTRUMENT PANEL

Most incidents are caused by contact and movement between:

1. The cluster lid A and instrument panel
2. Acrylic lens and combination meter housing
3. Instrument panel to front pillar garnish
4. Instrument panel to windshield
5. Instrument panel mounting pins
6. Wiring harnesses behind the combination meter
7. A/C defroster duct and duct joint

These incidents can usually be located by tapping or moving the components to duplicate the noise or by pressing on the components while driving to stop the noise. Most of these incidents can be repaired by applying felt cloth tape or silicon spray (in hard to reach areas). Urethane pads can be used to insulate wiring harness.

CAUTION:

Never use silicone spray to isolate a squeak or rattle. If the area is saturated with silicone, the recheck of repair becomes impossible.

CENTER CONSOLE

Components to pay attention to include:

1. Shifter assembly cover to finisher
2. A/C control unit and cluster lid C
3. Wiring harnesses behind audio and A/C control unit

The instrument panel repair and isolation procedures also apply to the center console.

DOORS

Pay attention to the following:

1. Finisher and inner panel making a slapping noise
2. Inside handle escutcheon to door finisher
3. Wiring harnesses tapping
4. Door striker out of alignment causing a popping noise on starts and stops

Tapping or moving the components or pressing on them while driving to duplicate the conditions can isolate many of these incidents. The areas can usually be insulated with felt cloth tape or insulator foam blocks from the Nissan Squeak and Rattle Kit (J-43980) to repair the noise.

TRUNK

Trunk noises are often caused by a loose jack or loose items put into the trunk by the customer.

In addition look for the following:

1. Trunk lid dumpers out of adjustment

SQUEAK AND RATTLE TROUBLE DIAGNOSES

< SYMPTOM DIAGNOSIS >

2. Trunk lid striker out of adjustment
3. The trunk lid torsion bars knocking together
4. A loose license plate or bracket

Most of these incidents can be repaired by adjusting, securing or insulating the item(s) or component(s) causing the noise.

SUNROOF/HEADLINING

Noises in the sunroof/headlining area can often be traced to one of the following:

1. Sunroof lid, rail, linkage or seals making a rattle or light knocking noise
2. Sunvisor shaft shaking in the holder
3. Front or rear windshield touching headlining and squeaking

Again, pressing on the components to stop the noise while duplicating the conditions can isolate most of these incidents. Repairs usually consist of insulating with felt cloth tape.

SEATS

When isolating seat noise it's important to note the position the seats in and the load placed on the seat when the noise occurs. These conditions should be duplicated when verifying and isolating the cause of the noise.

Cause of seat noise include:

1. Headrest rods and holder
2. A squeak between the seat pad cushion and frame
3. The rear seatback lock and bracket

These noises can be isolated by moving or pressing on the suspected components while duplicating the conditions under which the noise occurs. Most of these incidents can be repaired by repositioning the component or applying urethane tape to the contact area.

UNDERHOOD

Some interior noise may be caused by components under the hood or on the engine wall. The noise is then transmitted into the passenger compartment.

Causes of transmitted underhood noise include:

1. Any component mounted to the engine wall
2. Components that pass through the engine wall
3. Engine wall mounts and connectors
4. Loose radiator mounting pins
5. Hood bumpers out of adjustment
6. Hood striker out of adjustment

These noises can be difficult to isolate since they cannot be reached from the interior of the vehicle. The best method is to secure, move or insulate one component at a time and test drive the vehicle. Also, engine RPM or load can be changed to isolate the noise. Repairs can usually be made by moving, adjusting, securing, or insulating the component causing the noise.

A
B
C
D
E
F
G
H
I
IP
K
L
M
N
O
P

SQUEAK AND RATTLE TROUBLE DIAGNOSES

< SYMPTOM DIAGNOSIS >

Diagnostic Worksheet

INFOID:000000004250002



SQUEAK & RATTLE DIAGNOSTIC WORKSHEET

Dear Infiniti Customer:

We are concerned about your satisfaction with your Infiniti vehicle. Repairing a squeak or rattle sometimes can be very difficult. To help us fix your Infiniti right the first time, please take a moment to note the area of the vehicle where the squeak or rattle occurs and under what conditions. You may be asked to take a test drive with a service consultant or technician to ensure we confirm the noise you are hearing.

I. WHERE DOES THE NOISE COME FROM? (circle the area of the vehicle)

The illustrations are for reference only, and may not reflect the actual configuration of your vehicle.

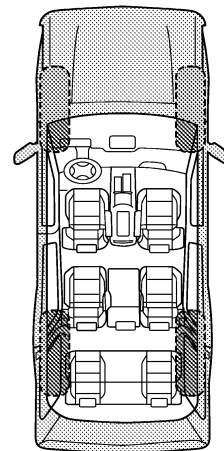
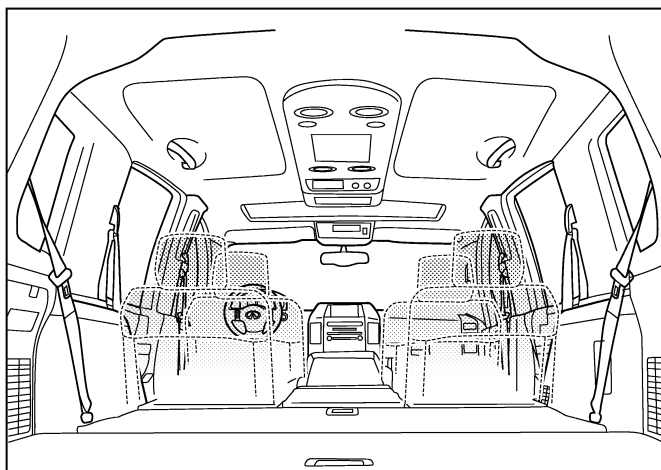
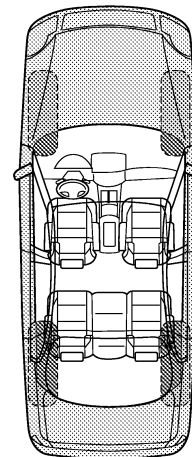
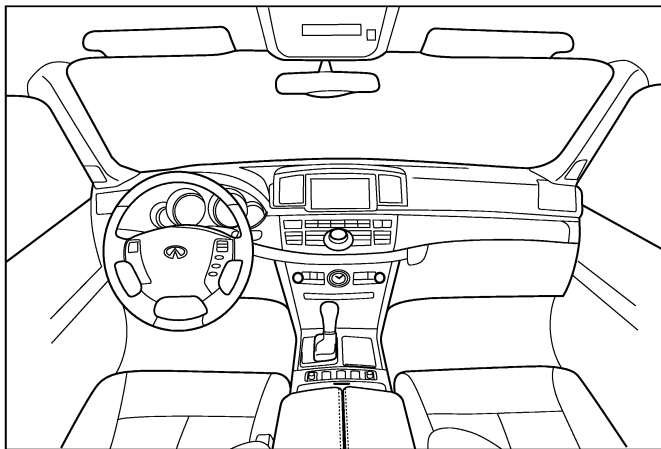

Continue to page 2 of the worksheet and briefly describe the location of the noise or rattle. In addition, please indicate the conditions which are present when the noise occurs.

PIIB8741E

SQUEAK AND RATTLE TROUBLE DIAGNOSES

< SYMPTOM DIAGNOSIS >

SQUEAK & RATTLE DIAGNOSTIC WORKSHEET - page 2

Briefly describe the location where the noise occurs:

II. WHEN DOES IT OCCUR? (please check the boxes that apply)

- | | |
|---|--|
| <input type="checkbox"/> anytime | <input type="checkbox"/> after sitting out in the rain |
| <input type="checkbox"/> 1st time in the morning | <input type="checkbox"/> when it is raining or wet |
| <input type="checkbox"/> only when it is cold outside | <input type="checkbox"/> dry or dusty conditions |
| <input type="checkbox"/> only when it is hot outside | <input type="checkbox"/> other: |

III. WHEN DRIVING:

- through driveways
- over rough roads
- over speed bumps
- only about ____ mph
- on acceleration
- coming to a stop
- on turns: left, right or either (circle)
- with passengers or cargo
- other: _____
- after driving ____ miles or ____ minutes

IV. WHAT TYPE OF NOISE

- squeak (like tennis shoes on a clean floor)
- creak (like walking on an old wooden floor)
- rattle (like shaking a baby rattle)
- knock (like a knock at the door)
- tick (like a clock second hand)
- thump (heavy, muffled knock noise)
- buzz (like a bumble bee)

TO BE COMPLETED BY DEALERSHIP PERSONNEL

Test Drive Notes:

	YES	NO	Initials of person performing
Vehicle test driven with customer	<input type="checkbox"/>	<input type="checkbox"/>	_____
- Noise verified on test drive	<input type="checkbox"/>	<input type="checkbox"/>	_____
- Noise source located and repaired	<input type="checkbox"/>	<input type="checkbox"/>	_____
- Follow up test drive performed to confirm repair	<input type="checkbox"/>	<input type="checkbox"/>	_____

VIN: _____ Customer Name: _____
W.O.# _____ Date: _____

This form must be attached to Work Order

PIIB8742E

A
B
C
D
E
F
G
H
I
IP
K
L
M
N
O
P

PRECAUTIONS

< PRECAUTION >

PRECAUTION

PRECAUTIONS

Precaution for Supplemental Restraint System (SRS) "AIR BAG" and "SEAT BELT PRE-TENSIONER"

INFOID:000000004250003

The Supplemental Restraint System such as "AIR BAG" and "SEAT BELT PRE-TENSIONER", used along with a front seat belt, helps to reduce the risk or severity of injury to the driver and front passenger for certain types of collision. This system includes seat belt switch inputs and dual stage front air bag modules. The SRS system uses the seat belt switches to determine the front air bag deployment, and may only deploy one front air bag, depending on the severity of a collision and whether the front occupants are belted or unbelted. Information necessary to service the system safely is included in the "SRS AIR BAG" and "SEAT BELT" of this Service Manual.

WARNING:

- To avoid rendering the SRS inoperative, which could increase the risk of personal injury or death in the event of a collision which would result in air bag inflation, all maintenance must be performed by an authorized NISSAN/INFINITI dealer.
- Improper maintenance, including incorrect removal and installation of the SRS, can lead to personal injury caused by unintentional activation of the system. For removal of Spiral Cable and Air Bag Module, see the "SRS AIR BAG".
- Do not use electrical test equipment on any circuit related to the SRS unless instructed to in this Service Manual. SRS wiring harnesses can be identified by yellow and/or orange harnesses or harness connectors.

PRECAUTIONS WHEN USING POWER TOOLS (AIR OR ELECTRIC) AND HAMMERS

WARNING:

- When working near the Air Bag Diagnosis Sensor Unit or other Air Bag System sensors with the ignition ON or engine running, DO NOT use air or electric power tools or strike near the sensor(s) with a hammer. Heavy vibration could activate the sensor(s) and deploy the air bag(s), possibly causing serious injury.
- When using air or electric power tools or hammers, always switch the ignition OFF, disconnect the battery, and wait at least 3 minutes before performing any service.

Precaution Necessary for Steering Wheel Rotation after Battery Disconnect

INFOID:000000004250004

NOTE:

- Before removing and installing any control units, first turn the push-button ignition switch to the LOCK position, then disconnect both battery cables.
- After finishing work, confirm that all control unit connectors are connected properly, then re-connect both battery cables.
- Always use CONSULT-III to perform self-diagnosis as a part of each function inspection after finishing work. If a DTC is detected, perform trouble diagnosis according to self-diagnosis results.

For vehicle with steering lock unit, if the battery is disconnected or discharged, the steering wheel will lock and cannot be turned.

If turning the steering wheel is required with the battery disconnected or discharged, follow the operation procedure below before starting the repair operation.

OPERATION PROCEDURE

1. Connect both battery cables.

NOTE:

Supply power using jumper cables if battery is discharged.

2. Turn the push-button ignition switch to ACC position.
(At this time, the steering lock will be released.)
3. Disconnect both battery cables. The steering lock will remain released with both battery cables disconnected and the steering wheel can be turned.
4. Perform the necessary repair operation.

PRECAUTIONS

< PRECAUTION >

5. When the repair work is completed, re-connect both battery cables. With the brake pedal released, turn the push-button ignition switch from ACC position to ON position, then to LOCK position. (The steering wheel will lock when the push-button ignition switch is turned to LOCK position.)
6. Perform self-diagnosis check of all control units using CONSULT-III.

Precaution for Battery Service

INFOID:000000004678497

Before disconnecting the battery, lower both the driver and passenger windows. This will prevent any interference between the window edge and the vehicle when the door is opened/closed. During normal operation, the window slightly raises and lowers automatically to prevent any window to vehicle interference. The automatic window function will not work with the battery disconnected.

Precaution

INFOID:000000004250005

- Disconnect both battery cables in advance.
- Disconnect air bag system line in advance.
- Never tamper with or force air bag lid open, as this may adversely affect air bag performance.
- Be careful not to scratch pad and other parts.
- When removing or disassembling any part, be careful not to damage or deform it. Protect parts, which may get in the way with cloth.
- When removing parts with a screwdriver or other tool, protect parts by wrapping them with vinyl or tape.
- Keep removed parts protected with cloth.
- If a clip is deformed or damaged, replace it.
- If an un reusable part is removed, replace it with a new one.
- Tighten bolts and nuts firmly to the specified torque.
- After re-assembly has been completed, make sure each part functions correctly.
- Remove stains in the following way.

Water-soluble stains:

Dip a soft cloth in warm water, and then squeeze it tightly. After wiping the stain, wipe with a soft dry cloth.

Oil stain:

Dissolve a synthetic detergent in warm water (density of 2 to 3% or less), dip the cloth, then clean off the stain with the cloth. Next, dip the cloth in fresh water and squeeze it tightly. Then clean off the detergent completely. Then wipe the area with a soft dry cloth.

- Never use any organic solvent, such as thinner or benzine.

A
B
C
D
E
F
G
H
I
IP
K
L
M
N
O
P

PREPARATION

< PREPARATION >

PREPARATION

PREPARATION

Special Service Tools

INFOID:00000000425006

The actual shapes of Kent-Moore tools may differ from those of special service tools illustrated here.

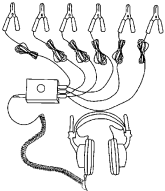
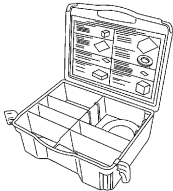
Tool number (Kent-Moore No.) Tool name	Description
(J-39570) Chassis ear  SIIA0993E	Locates the noise
(J-43980) NISSAN Squeak and Rattle Kit  SIIA0994E	Repairs the cause of noise

Commercial Service Tools

INFOID:00000000425007

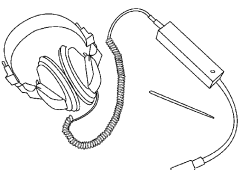
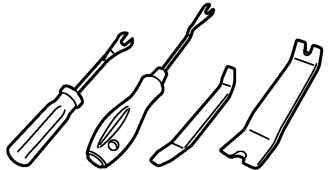
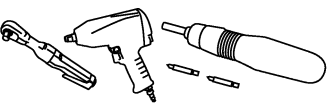
Tool name	Description
Engine ear  SIIA0995E	Locates the noise
Remover tool  JMKIA3050ZZ	Removes clips, pawls, and metal clips
Power tool  PIIB1407E	

INSTRUMENT PANEL ASSEMBLY

< REMOVAL AND INSTALLATION >

REMOVAL AND INSTALLATION

INSTRUMENT PANEL ASSEMBLY

Exploded View

INFOID:000000004250008

SEC. 680

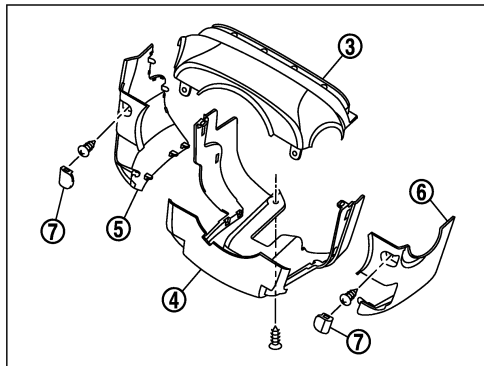
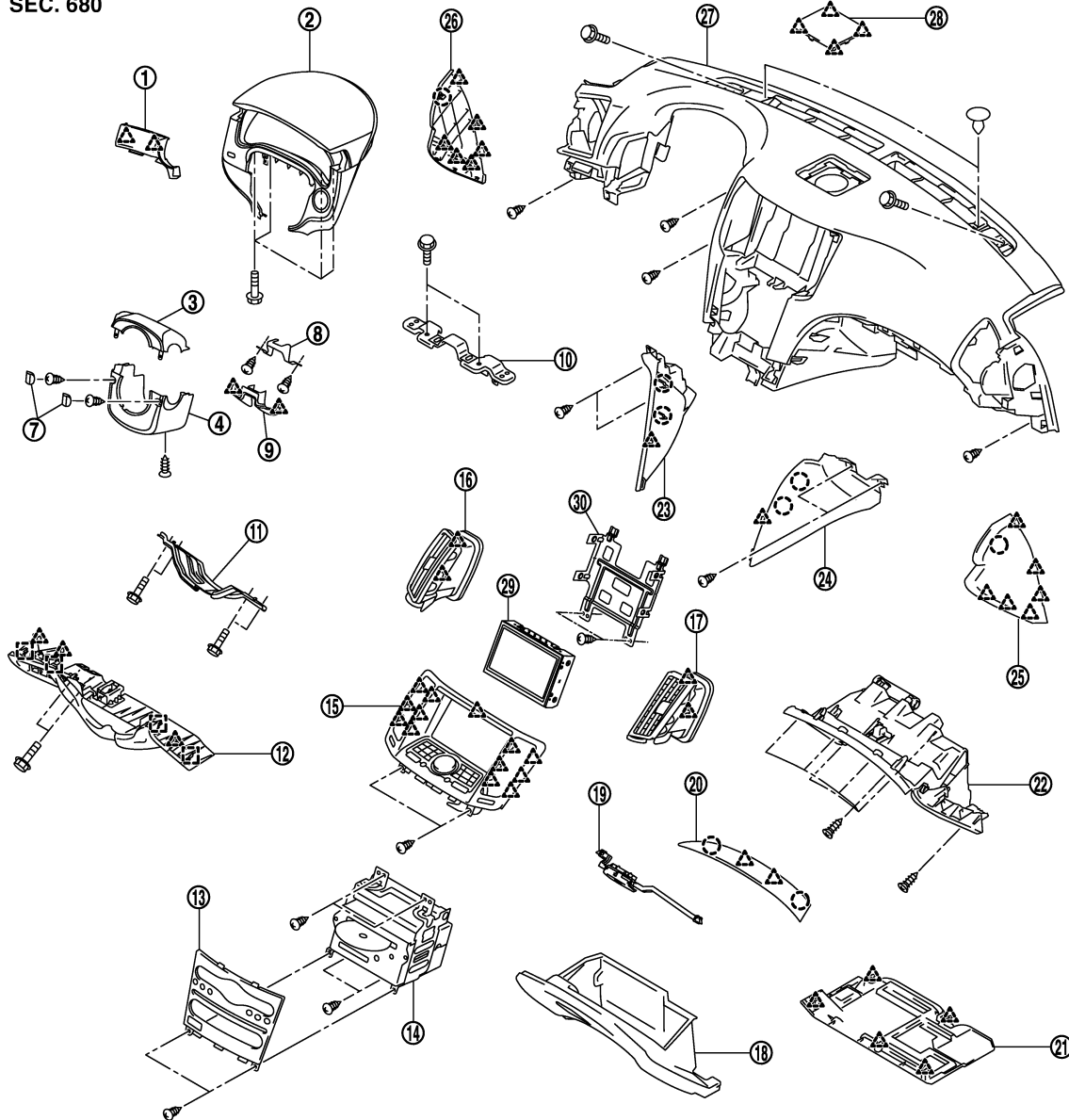



A
B
C
D
E
F
G
H
I
IP
K
L
M
N
O
P

INSTRUMENT PANEL ASSEMBLY

< REMOVAL AND INSTALLATION >

- | | | |
|---------------------------------|--------------------------------------|--------------------------------------|
| 1. Instrument finisher A | 2. Cluster lid A (Combination meter) | 3. Steering column cover upper |
| 4. Steering column cover lower | 5. Steering column side cover LH | 6. Steering column side cover RH |
| 7. Steering column mask | 8. Cluster lid A lower bracket | 9. Steering column front lower cover |
| 10. Meter bracket | 11. Knee protector | 12. Instrument lower panel LH |
| 13. Cluster lid C | 14. AV control unit | 15. Cluster lid D |
| 16. Center ventilator grille LH | 17. Center ventilator grille RH | 18. Glove box assembly |
| 19. Glove box lock assembly | 20. Instrument finisher B | 21. Instrument lower cover |
| 22. Instrument lower panel RH | 23. Instrument side panel LH | 24. Instrument side panel RH |
| 25. Instrument side finisher RH | 26. Instrument side finisher LH | 27. Instrument panel assembly |
| 28. Center speaker grille | 29. Display unit | 30. Display unit bracket |

 : Clip

 : Pawl

 : Metal clip

Removal and Installation

INFOID:000000004250009

CAUTION:

When removing, always use a remover tool that is made of plastic.

WORK STEP

When removing instrument panel assembly, combination meter, audio unit, and center console take steps in the order shown by the number below.

PARTS	INSTRUMENT PANEL ASSEMBLY	COMBINATION METER	AV CONTROL UNIT	CENTER CONSOLE
Selector/shift lever Knob	[1]		[1]	[1]
Console finisher	[2]		[2]	[2]
Rear upper console assembly (7AT models only)	[3]			[3]
Coin pocket (6MT models only)	[4]			[4]
Console rear finisher	[5]			[5]
Console mask	[6]			[6]
Center console assembly	[7]			[7]
Cluster lid C	[8]		[3]	
Cluster lid D	[9]		[4]	
Display unit	[10]		[5]	
AV control unit	[11]		[6]	
Body side welt LH	[12]			
Front pillar garnish LH	[13]			
Instrument side finisher LH	[14]			
Instrument lower panel LH	[15]			
Instrument finisher A	[16]			
Instrument side panel LH	[17]			
Steering wheel assembly	[18]	[1]		
Steering column cover	[19]	[2]		
Combination switch	[20]	[3]		
Spiral cable	[21]			
Paddle switch (7AT models only)	[22]	[4]		
Knee protector	[23]	[5]		

INSTRUMENT PANEL ASSEMBLY

< REMOVAL AND INSTALLATION >

Cluster lid A (Combination meter)	[24]	[6]		
Meter bracket	[25]			
Front defroster grille (LH/RH)	[26]			
Body side welt RH	[27]			
Front pillar garnish RH	[28]			
Instrument side finisher RH	[29]			
Instrument lower cover	[30]			
Glove box assembly	[31]			
Instrument lower assist panel	[32]			
Instrument finisher RH	[33]			
Instrument side panel RH	[34]			
Instrument panel assembly	[35]			

[]: Number indicates step in removal procedures.

REMOVAL

- Put selector lever in drive position (7AT models only).
- Remove selector lever knob (7AT models only).
 - 2WD models: Refer to [TM-277, "2WD : Exploded View"](#).
 - AWD models: Refer to [TM-279, "AWD : Exploded View"](#).
- Remove shift lever knob (6MT models only). Refer to [TM-18, "Exploded View"](#).
- Remove console finisher.

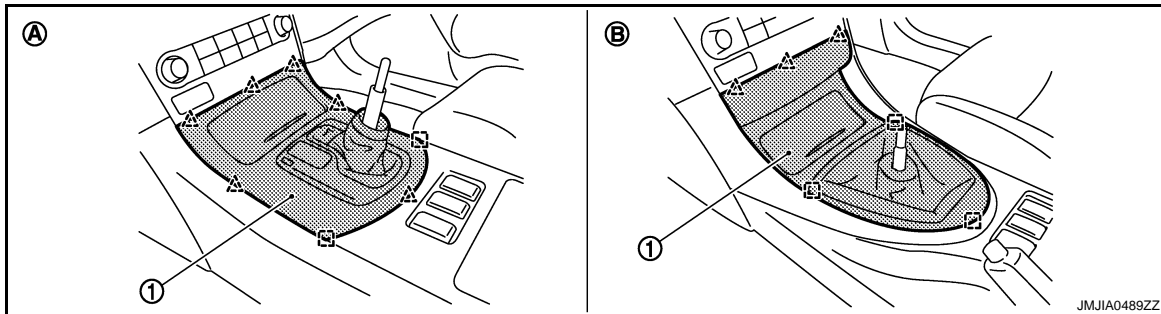

(A) Console finisher (7AT models)

(B) Console finisher (6MT models)

- Remove clips from rear of console finisher (1), and then remove pawl of front.
- Pull console finisher (1) upward to disengage from center console.
- Disconnect harness connectors.

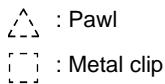

- Remove screws (B) of center console front side with screw driver (A).

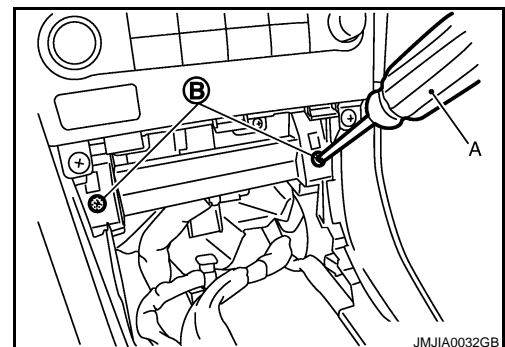

INSTRUMENT PANEL ASSEMBLY

< REMOVAL AND INSTALLATION >

6. Remove rear upper console assembly (7AT models only).
- Slide forward, pull up rear upper console assembly (1), and disconnect metal clips.
 - Disconnect heated seat switch harness connectors. (with heated seat)

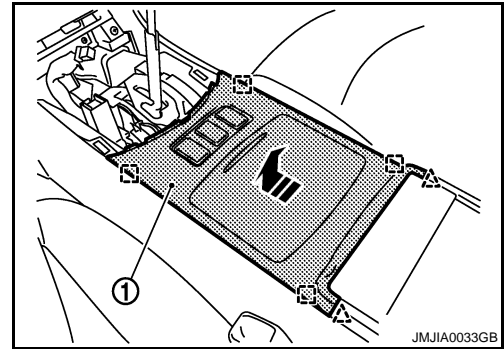
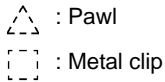

7. Disconnect auxiliary input jacks connector (A) and power socket harness connector (B) (7AT models only).

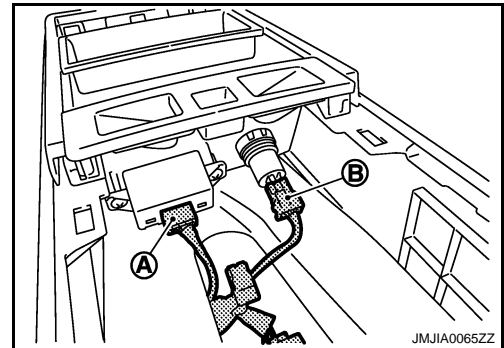

8. Disconnect console sub harness connectors (A) (6MT models only).

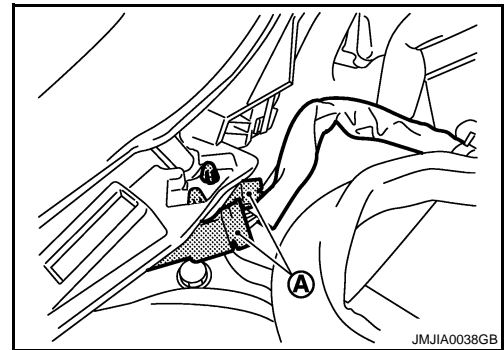

9. Disconnect heated seat switch connector (A) (6MT models with heated seat only).

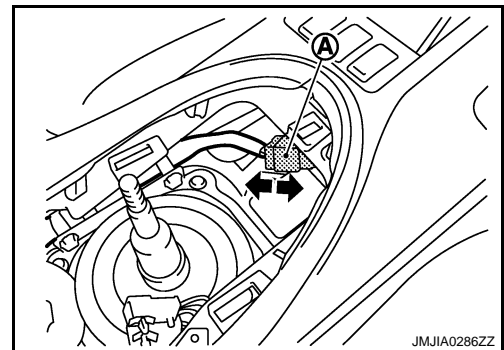

10. Remove coin pocket fixing pawl using a remover tool (A), and then remove coin pocket (1) (6MT models only).

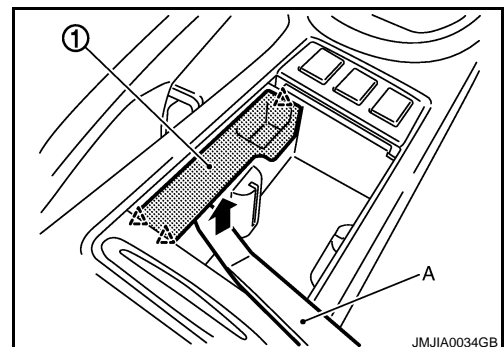
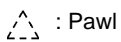

INSTRUMENT PANEL ASSEMBLY

< REMOVAL AND INSTALLATION >

11. Insert a deep-well socket wrench (A) to rotate adjusting nut to loosen cable sufficiently (6MT models only).
Refer to [PB-4, "LEVER TYPE : Inspection and Adjustment"](#).

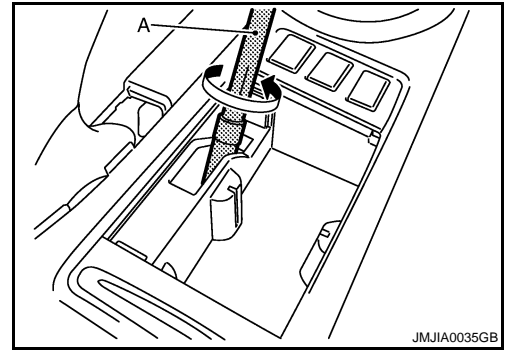

12. Remove console rear finisher.
 - Pull back the console rear finisher (1).
 - Disconnect inside key antenna connector (A).

 : Metal clip

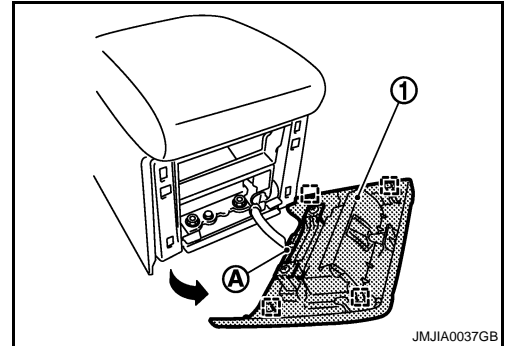

13. Remove console mask.

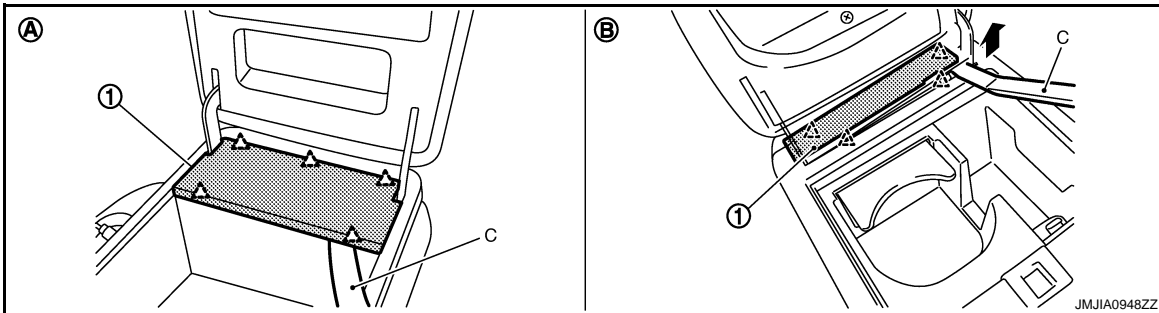

(A) Console mask (7AT models)

(B) Console mask (6MT models)

- Open the console lid.
- Pull up console mask (1) by using a remover tool (C), and disengage pawls.

 : Pawl

14. Remove screws (C) of center console rear side, and then remove center console assembly (1).

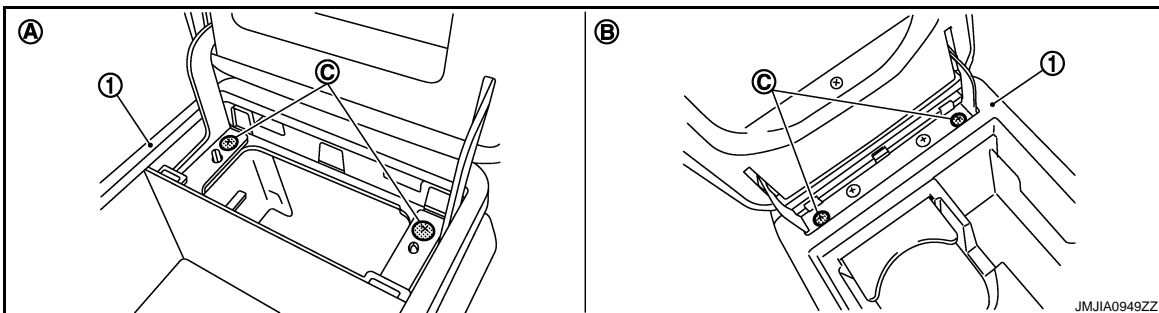

(A) Console mounting screws (7AT models)

(B) Console mounting screws (6MT models)

INSTRUMENT PANEL ASSEMBLY

< REMOVAL AND INSTALLATION >

15. Remove cluster lid C.

- Remove cluster lid C mounting screws (A).
- Pull back cluster lid C (1).
- Disconnect harness connectors.

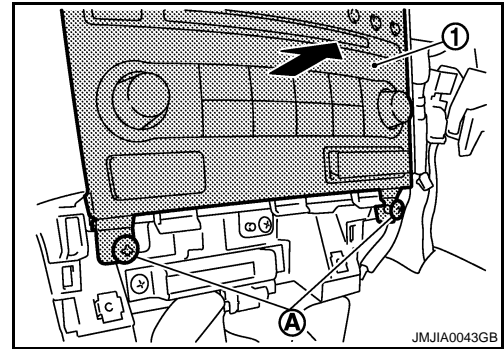

16. Remove cluster lid D.

- Remove cluster lid D mounting screws (A).
- Pull back cluster lid D (1).
- Disconnect harness connectors.

 : Pawl

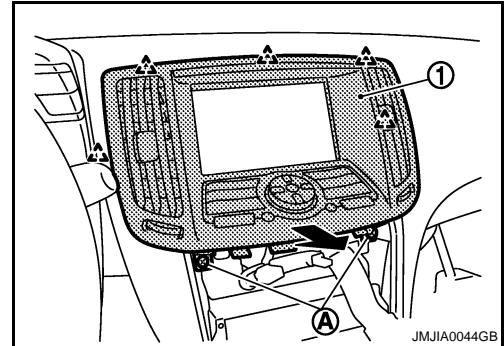

17. Remove display unit. Refer to [AV-112, "Removal and Installation"](#).

18. Disconnect center speaker harness connector (A). (with center speaker)

19. Remove screw (B).

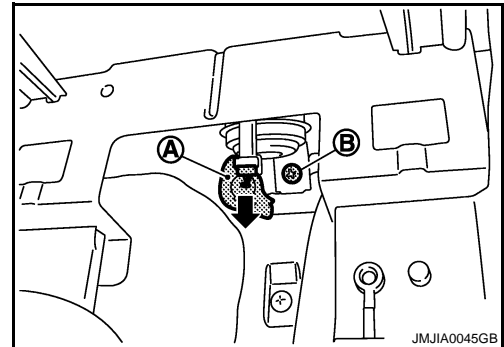

20. Disconnect inside key antenna connector (A) and clip (B) located under audio unit.

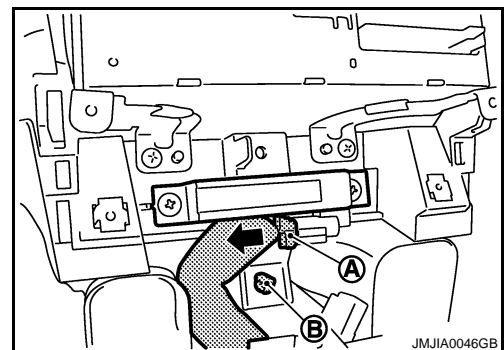

21. Remove AV control unit. Refer to [AV-348, "Removal and Installation"](#).

22. Remove body side welt LH. Refer to [INT-14, "Removal and Installation"](#).

23. Remove front pillar garnish LH. Refer to [INT-14, "Removal and Installation"](#).

INSTRUMENT PANEL ASSEMBLY

< REMOVAL AND INSTALLATION >

24. Disconnect antenna harness connectors (A) and then remove harness clips.

 : Clip

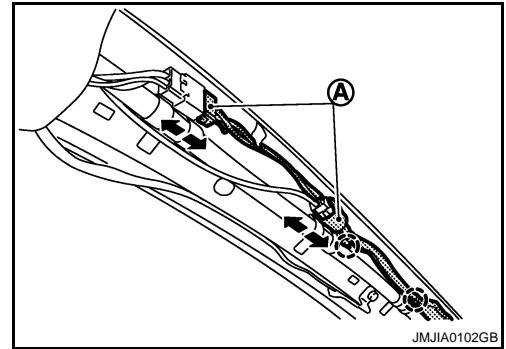

25. Remove instrument side finisher LH.
- Insert a remover tool into lower space.
 - Pull the instrument side finisher LH (1) crosswise.

 : Clip

 : Pawl

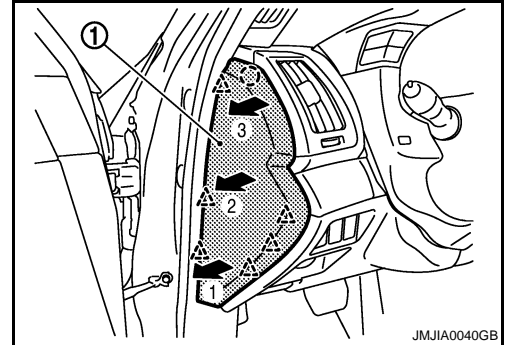

26. Remove instrument lower panel LH.
- Remove hood opener mounting bolts (A).
 - Refer to [DLK-209, "HOOD LOCK CONTROL : Removal and Installation"](#).
 - Remove data link connector mounting screws (B).
 - Pull back instrument lower panel LH (1).
 - Disconnect harness connectors.

 : Pawl

 : Metal clip

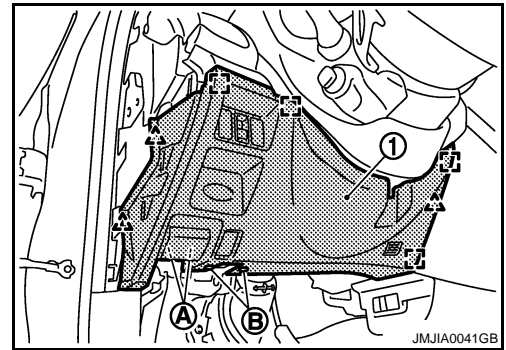

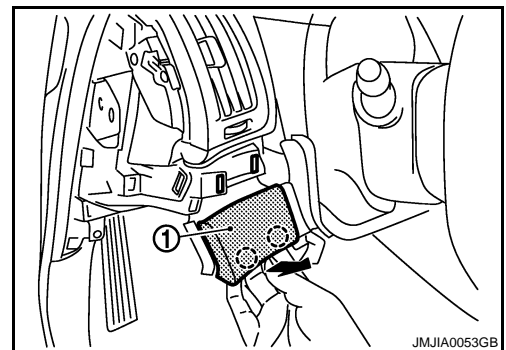

27. Remove instrument finisher A.
- Pull instrument finisher A (1) upward, and then disengage pawls.

 : Clip



28. Remove instrument side panel LH.
- Remove instrument side panel mounting screws (A).
 - Pull the instrument side panel LH (1) crosswise.

 : Clip

 : Pawl

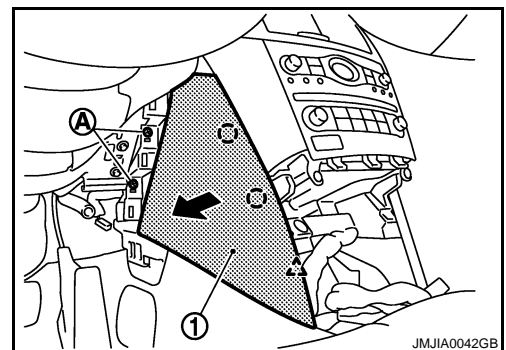

A
B
C
D
E
F
G
H
I
IP
K
L
M
N
O
P

INSTRUMENT PANEL ASSEMBLY

< REMOVAL AND INSTALLATION >

29. Remove steering wheel assembly. Refer to [ST-17. "Removal and Installation"](#).
30. Remove steering column covers.

CAUTION:

When removing the column covers, to facilitate the work operation remove first the steering wheel.

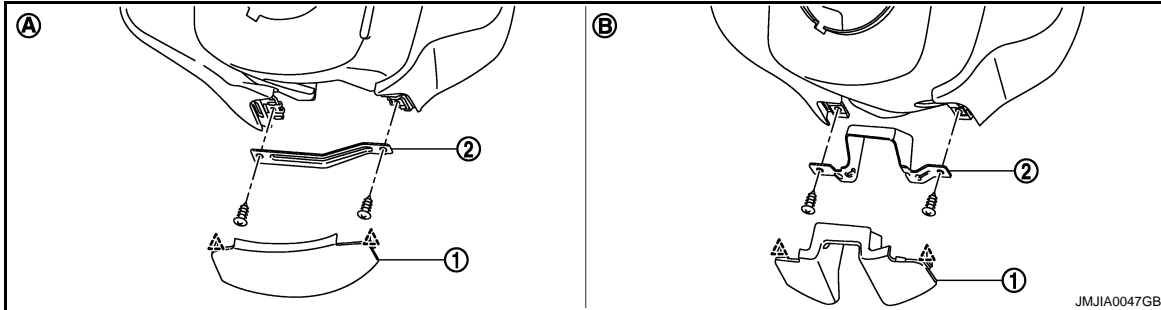

(A) Column cover (with electric column)

(B) Column cover (with manual column)

- Remove steering column front lower cover (1).
- Remove cluster lid A lower bracket (2).

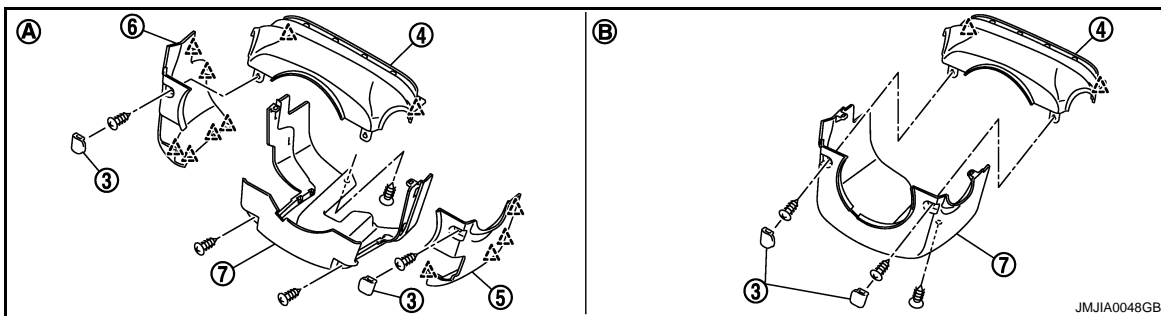

(A) Column cover (with PADDLE SHIFTER)

(B) Column cover (without PADDLE SHIFTER)

- Remove steering column mask (3) and screws.
- Pull up steering column cover upper (4).
- Remove steering column side cover RH (5) (with PADDLE SHIFTER).
- Pull the steering column side cover LH (6) to the left side (with PADDLE SHIFTER).
- Disconnect ADP steering switch connector (with ADP).
- Remove steering column side cover LH (6).
- Remove screws, and then remove steering column lower cover (7).

 : Pawl

31. Remove combination switch. Refer to [BCS-82. "Exploded View"](#).
32. Remove spiral cable and steering angle sensor. Refer to [SR-15. "Exploded View"](#).

CAUTION:

Perform 4WAS front actuator adjustment. Refer to [STC-28. "4WAS FRONT ACTUATOR NEUTRAL POSITION ADJUSTMENT : Description"](#).

33. Remove paddle switch LH/RH (with PADDLE SHIFTER). Refer to [TM-282. "Exploded View"](#).
34. Remove cluster lid A (Combination meter).

INSTRUMENT PANEL ASSEMBLY

< REMOVAL AND INSTALLATION >

- Remove knee protector mounting bolts (A) with power tool, and then remove knee protector (1).

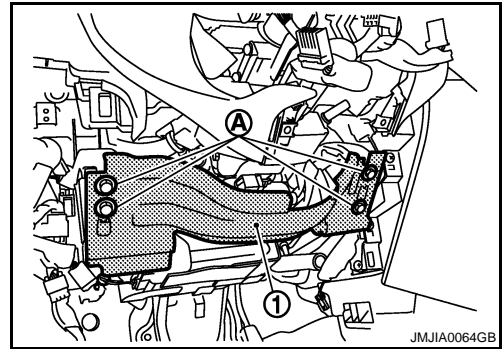

- Disengage harness cover mounting pawl (B) by using tool (A) located under the column shaft.
- Pull down harness cover (1) (with harness cover)

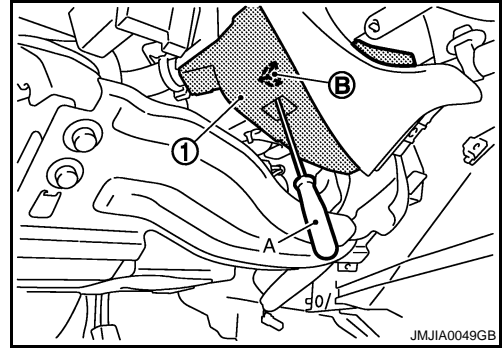

- Remove cluster lid A (combination meter) mounting bolts (A).

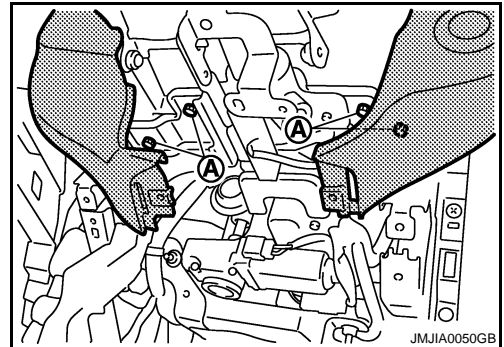

- Disconnect push button ignition switch harness connector (A).
- Pull back cluster lid A (combination meter), and disconnect combination meter connectors.

NOTE:

For removal and installation of combination meter, refer to [MWI-125, "Removal and Installation"](#).

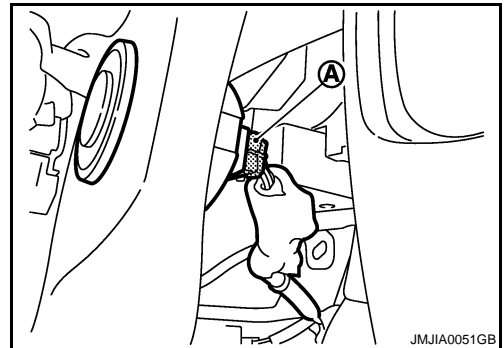

A
B
C
D
E
F
G
H
I
IP
K
L
M
N
O
P

INSTRUMENT PANEL ASSEMBLY

< REMOVAL AND INSTALLATION >

35. Remove meter bracket mounting bolts (A), and then remove meter bracket (1).

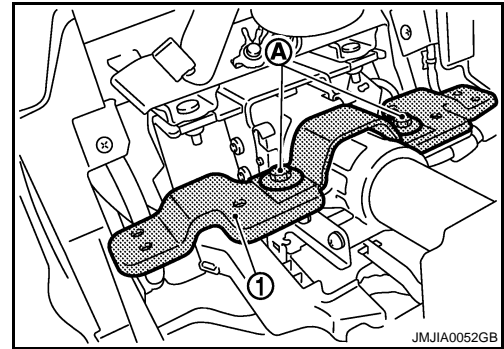

36. Remove front defroster grille LH. Refer to [VTL-12. "FRONT DEFROSTER GRILLE : Removal and Installation"](#).
- Pull upward, disengage pawls.
 - Disconnect harness connector.
37. Remove front defroster grille RH. Refer to [VTL-12. "FRONT DEFROSTER GRILLE : Removal and Installation"](#).
- Pull upward, disengage pawls.
 - Disconnect harness connector.
38. Remove body side welt RH. Refer to [INT-14. "Removal and Installation"](#).
39. Remove front pillar garnish RH. Refer to [INT-14. "Removal and Installation"](#).
40. Remove instrument side finisher RH.
- Insert a remover tool into lower space.
 - Pull the instrument side finisher RH (1) crosswise.

○ : Clip

△ : Pawl

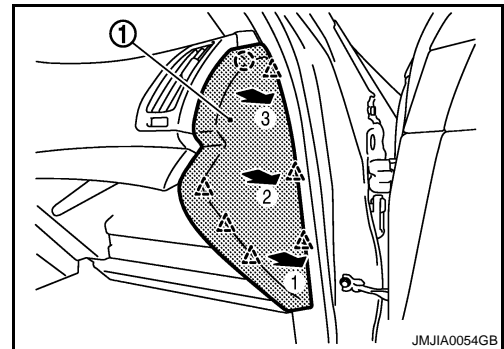

41. Remove instrument lower cover.
- Pull downward, disengage pawls.
 - Pull back instrument lower cover (1).

△ : Pawl

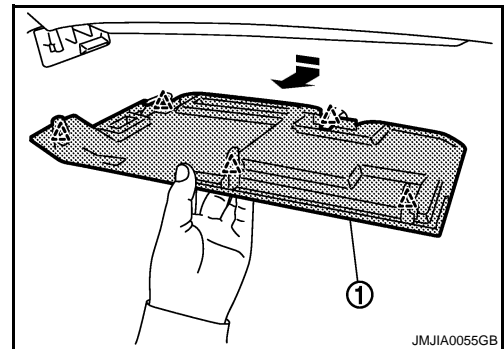

42. Remove glove box assembly.
- Open the glove box.

INSTRUMENT PANEL ASSEMBLY

< REMOVAL AND INSTALLATION >

- Pull up glove box assembly (1).

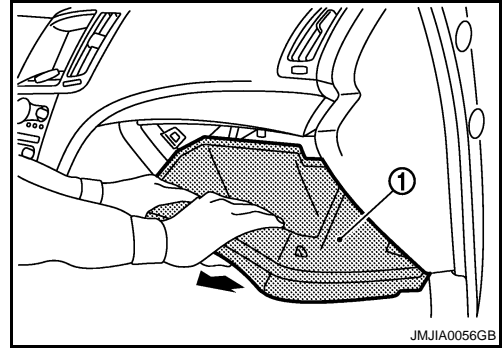

- Remove damper pin (2) of left side.

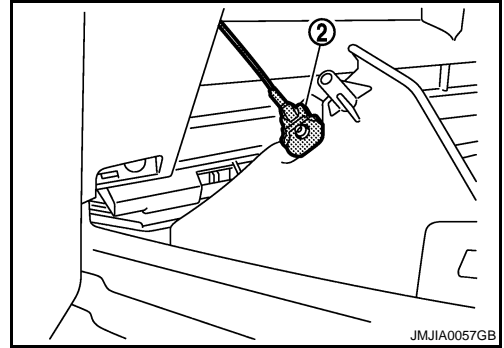

43. Remove instrument lower panel RH.
- Remove instrument lower panel RH mounting screws (A) with power tool.
 - Pull back instrument lower panel RH (1).
 - Disconnect harness connector.

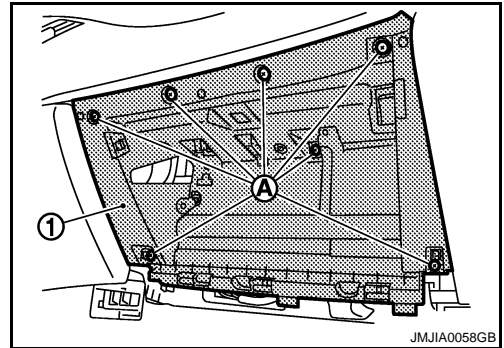

44. Remove instrument finisher B.
- Pull instrument finisher B (1) upward then disengage pawls.

- : Clip
- △ : Pawl

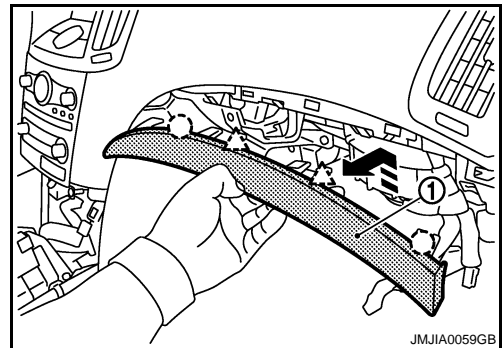

45. Remove instrument side panel RH.
- Remove instrument side panel mounting screws (A).
 - Pull the instrument side panel RH (1) crosswise.

- : Clip
- △ : Pawl

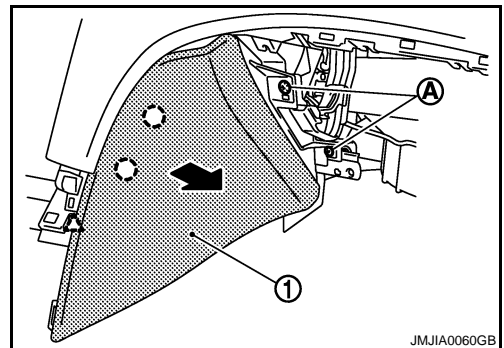

A
B
C
D
E
F
G
H
I
IP
K
L
M
N
O
P

INSTRUMENT PANEL ASSEMBLY

< REMOVAL AND INSTALLATION >

46. Disconnect passenger air bag module connector. Refer to [SR-18. "Removal and Installation"](#).
47. Remove passenger air bag module fixing bolt. Refer to [SR-18. "Exploded View"](#).
48. Remove instrument panel assembly.
 - Remove defroster nozzle mounting clips (A).
 - Remove screws (B) and bolts (C) with power tool, and then remove instrument panel assembly (1).

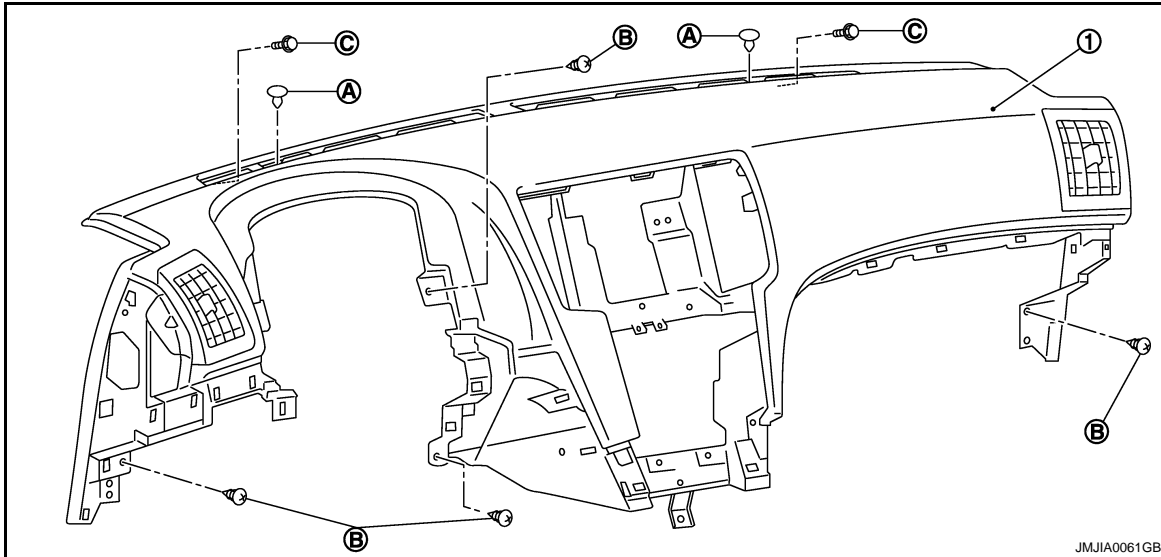

CAUTION:

When removing instrument panel, 2 workers are required so as to prevent it from dropping.

49. Remove the following parts after removing instrument panel assembly.
 - Antenna feeder
 - Center speaker grille
 - Center speaker: Refer to [AV-354. "Removal and Installation"](#).
 - Front passenger air bag module: Refer to [SR-18. "Removal and Installation"](#).
 - Side ventilator grille LH/RH: Refer to [VTL-11. "SIDE VENTILATOR GRILLE : Removal and Installation"](#).
 - Inside key antenna: Refer to [DLK-238. "INSTRUMENT CENTER : Removal and Installation"](#).
 - Combination meter: Refer to [MWI-125. "Removal and Installation"](#).

INSTALLATION

Install in the reverse order of removal.

CENTER CONSOLE ASSEMBLY

< REMOVAL AND INSTALLATION >

CENTER CONSOLE ASSEMBLY



Exploded View

INFOID:000000004250010

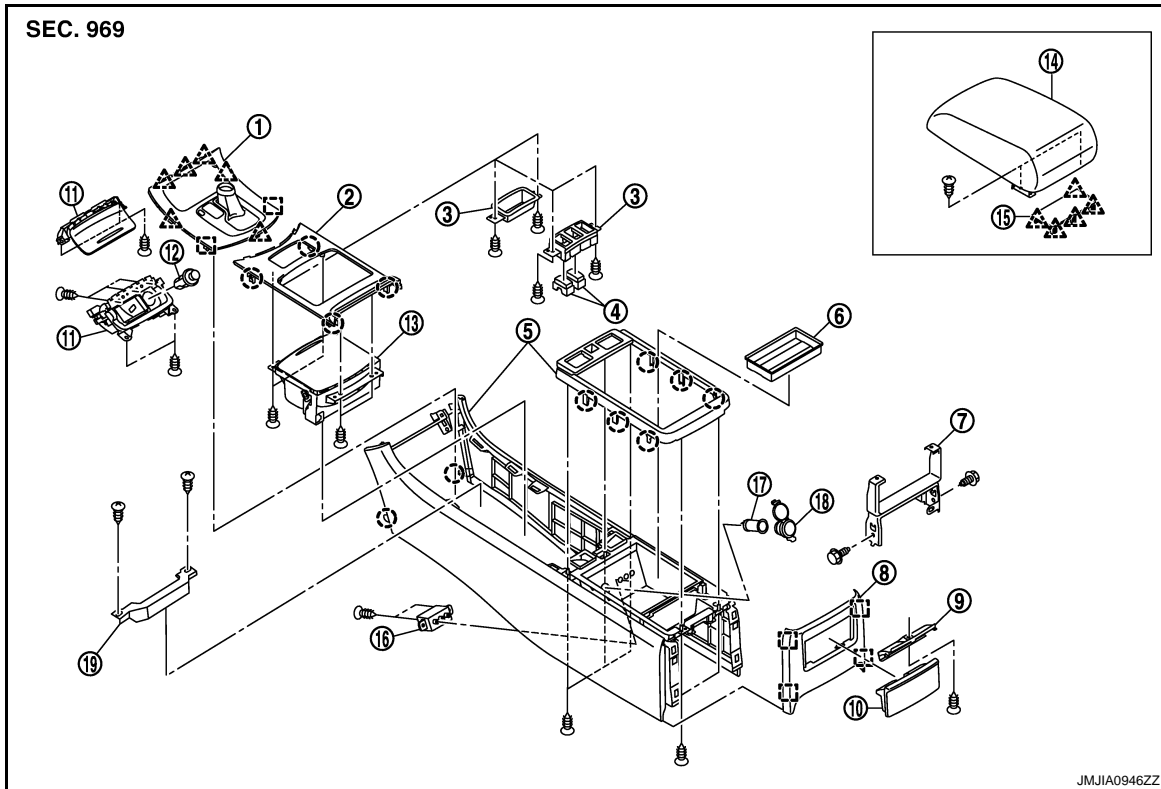
CENTER CONSOLE (7AT MODELS)



- | | | |
|------------------------------|--------------------------------|----------------------------|
| 1. Console finisher assembly | 2. Rear upper console assembly | 3. Switch panel |
| 4. Switch hole mask | 5. Center console assembly | 6. Console pocket |
| 7. Console rear bracket | 8. Console rear finisher | 9. Console ashtray bracket |
| 10. Console ashtray | 11. Ashtray (front) | 12. Cigarette lighter |
| 13. Cup holder assembly | 14. Console lid | 15. Console mask |
| 16. Auxiliary input jacks | 17. Cigarette lighter case | 18. Socket knob |
| 19. Console front bracket | | |

-  : Clip
-  : Pawl
-  : Metal clip

CENTER CONSOLE (6MT MODELS)

A
B
C
D
E
F
G
H
I
IP
K
L
M
N
O
P

CENTER CONSOLE ASSEMBLY

< REMOVAL AND INSTALLATION >

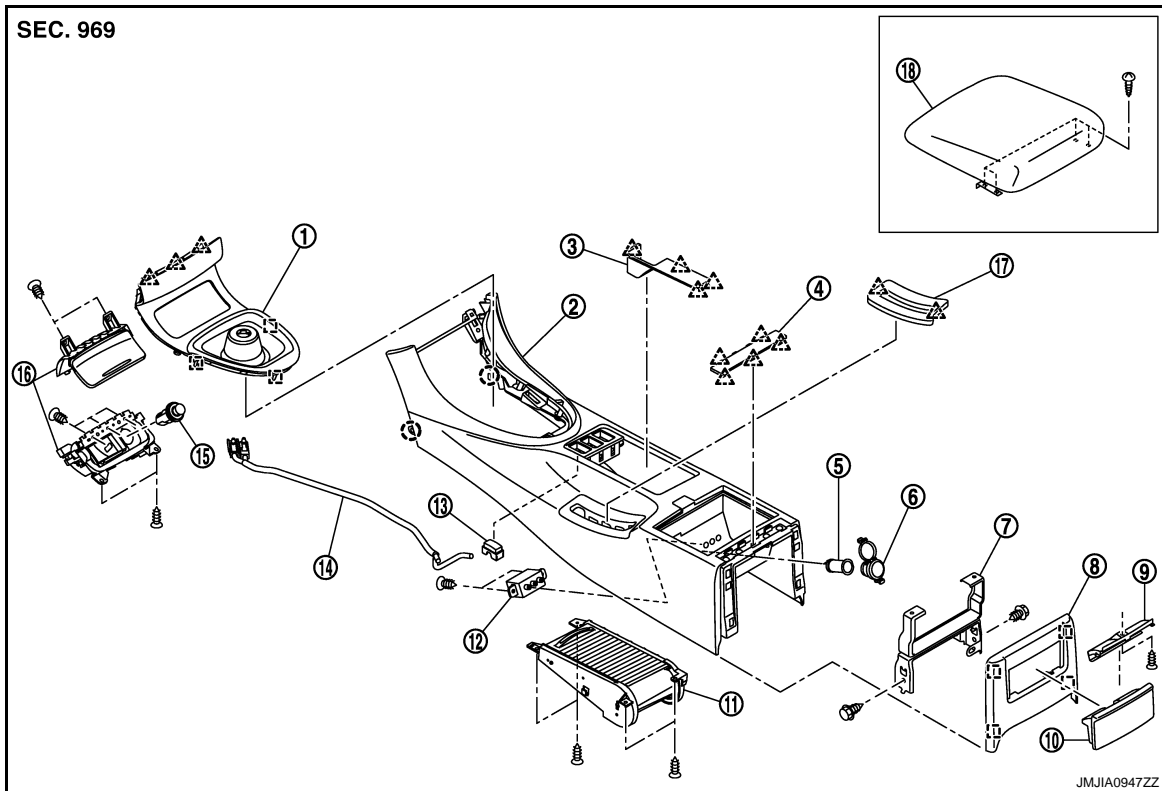

- | | | |
|------------------------------|----------------------------------|----------------------------|
| 1. Console finisher assembly | 2. Center console assembly | 3. Coin pocket |
| 4. Console mask | 5. Cigarette lighter case | 6. Socket knob |
| 7. Console rear bracket | 8. Console rear finisher | 9. Console ashtray bracket |
| 10. Console ashtray | 11. Cup holder assembly | 12. Auxiliary input jacks |
| 13. Switch hole mask | 14. Console sub harness | 15. Cigarette lighter |
| 16. Ashtray (front) | 17. Parking brake lever finisher | 18. Console lid |

- : Clip
△ : Pawl
□ : Metal clip

Removal and Installation

INFOID:000000004250011

CAUTION:

When removing, always use a remover tool that is made of plastic.

REMOVAL

1. Put selector lever in drive position (7AT models only).
2. Remove selector lever knob (7AT models only).
 - 2WD models: Refer to [TM-277, "2WD : Exploded View"](#).
 - AWD models: Refer to [TM-279, "AWD : Exploded View"](#).
3. Remove shift lever knob (6MT models only). Refer to [TM-18, "Exploded View"](#).
4. Remove console finisher.

CENTER CONSOLE ASSEMBLY

< REMOVAL AND INSTALLATION >

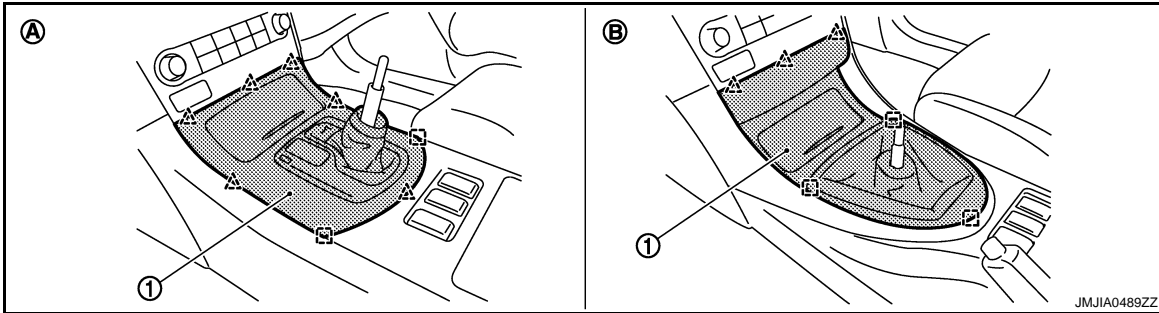

(A) Console finisher (7AT models)

(B) Console finisher (6MT models)

- Remove clips from rear of console finisher (1), and then remove pawl of front.
- Pull console finisher (1) upward to disengage from center console.
- Disconnect harness connectors.

 : Pawl

 : Metal clip

5. Remove screws (B) of center console front side with screw driver (A).

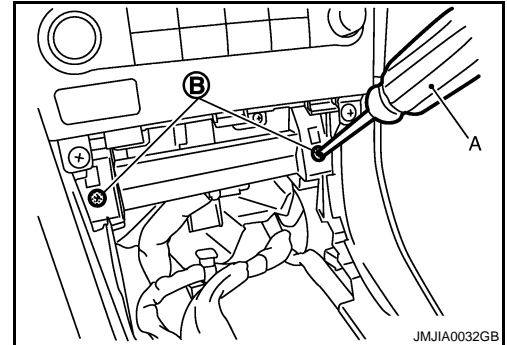

6. Remove rear upper console assembly (7AT models only).
- Slide to front, pull up rear upper console assembly (1), and disconnect metal clips.
 - Disconnect heated seat switch harness connectors. (with heated seat)

 : Pawl

 : Metal clip

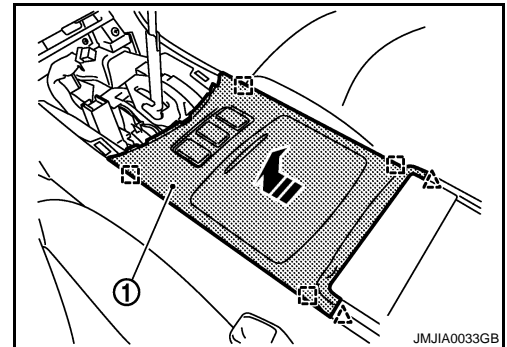

7. Disconnect auxiliary input jacks connector (A) and power socket harness connector (B) (7AT models only).

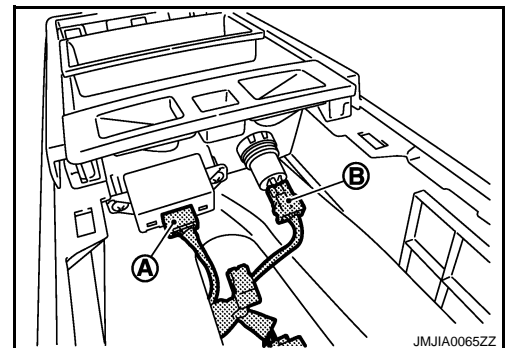

A
B
C
D
E
F
G
H
I
P
K
L
M
N
O
P

CENTER CONSOLE ASSEMBLY

< REMOVAL AND INSTALLATION >

8. Disconnect console sub harness connectors (A) (6MT models only).

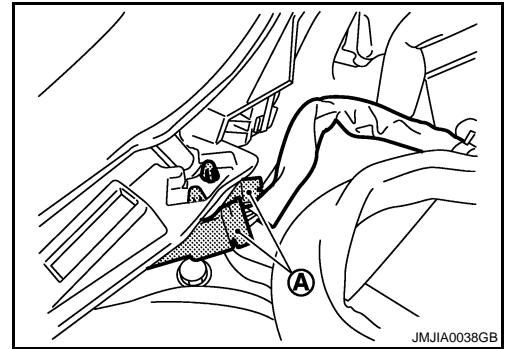

9. Disconnect heated seat switch connector (A) (6MT models with heated seat only).

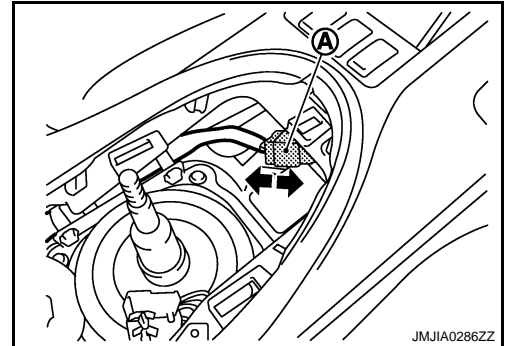

10. Remove coin pocket fixing pawl using a remover tool (A), and then remove coin pocket (1) (6MT models only).

 : Pawl

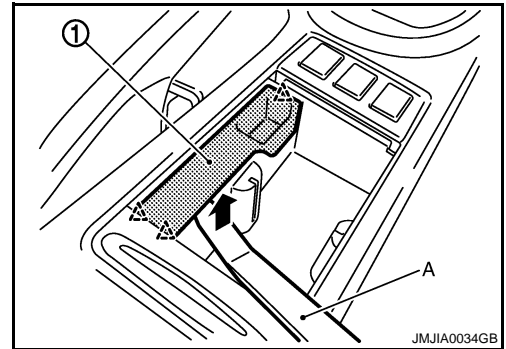

11. Insert a deep-well socket wrench (A) to rotate adjusting nut to loosen cable sufficiently (6MT models only).
Refer to [PB-4, "LEVER TYPE : Inspection and Adjustment"](#).

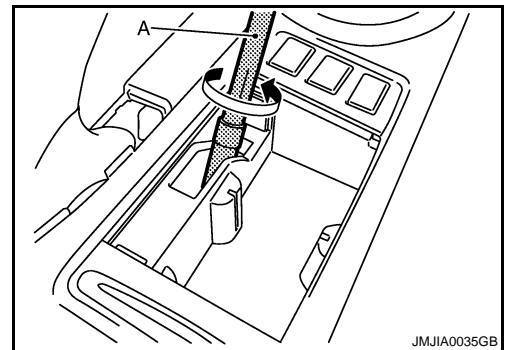

12. Remove console rear finisher.
• Pull back the console rear finisher (1).
• Disconnect inside key antenna connector (A).

 : Metal clip

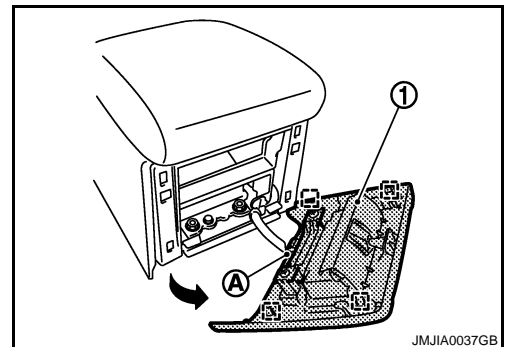

CENTER CONSOLE ASSEMBLY

< REMOVAL AND INSTALLATION >

13. Remove console mask.

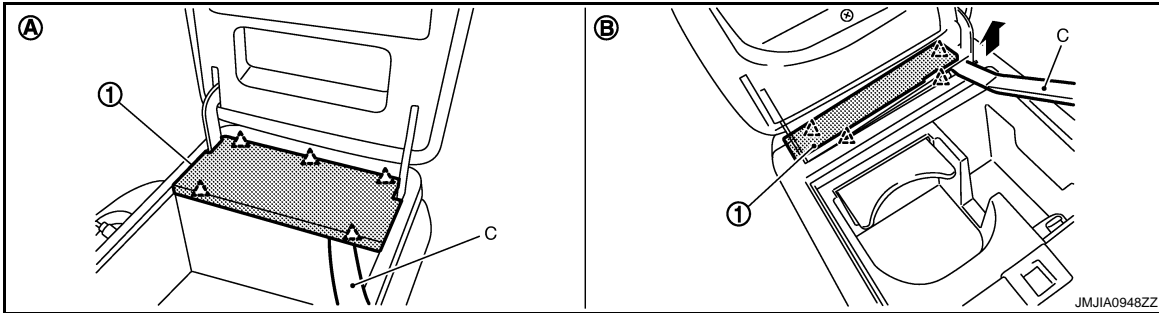

(A) Console mask (7AT models)

(B) Console mask (6MT models)

- Open the console lid.
- Pull up console mask (1) by using a remover tool (C), and disengage pawls.

 : Pawl

14. Remove screws (C) of center console rear side, and then remove center console assembly (1).

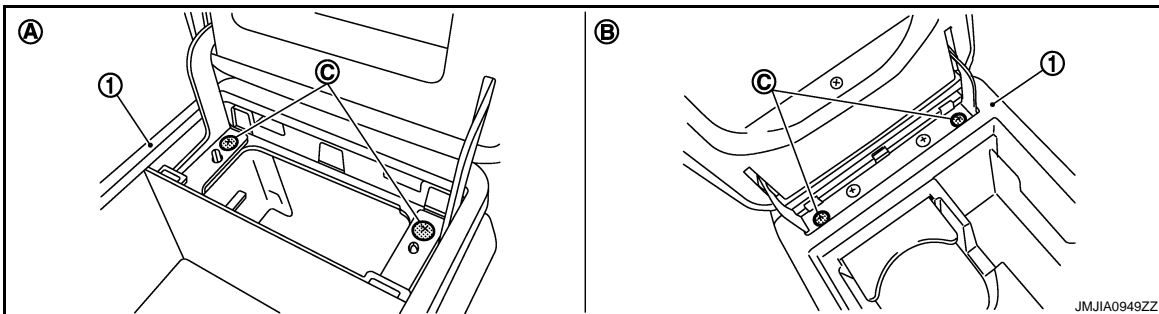

(A) Console mounting screws (7AT models)

(B) Console mounting screws (6MT models)

INSTALLATION

Install in the reverse order of removal.

Disassembly and Assembly

INFOID:000000004250012

CAUTION:

When disassembling, always use a remover tool that is made of plastic.

DISASSEMBLY AND ASSEMBLY OF CENTER CONSOLE (7AT MODELS)

Disassembly

1. Remove screws of console finisher assembly back side, and remove ashtray (front portion).
2. Remove rear upper console assembly. Refer to [IP-12](#).
3. Remove screws and remove cup holder assembly.
4. Remove screws and remove console front bracket.
5. Remove console mask. Refer to [IP-12](#).
6. Remove console lid mounting screws and remove console lid.
7. Remove metal clips and remove console rear finisher. Refer to [IP-12](#).
8. Remove console ashtray.
9. Remove screw and remove console ashtray bracket.
10. Remove console pocket from center console assembly.
11. Remove auxiliary input jacks and socket knob, cigarette lighter case.

Assembly

CENTER CONSOLE ASSEMBLY

< REMOVAL AND INSTALLATION >

Assemble in the reverse order of disassembly.

DISASSEMBLY AND ASSEMBLY OF CENTER CONSOLE (6MT MODELS)

Disassembly

1. Remove screws of console finisher assembly back side, and remove ashtray (front portion).
2. Remove coin pocket. Refer to [IP-12](#).
3. Remove console mask. Refer to [IP-12](#).
4. Remove console lid mounting screws and remove console lid.
5. Remove metal clips and remove console rear finisher. Refer to [IP-12](#).
6. Remove console ashtray.
7. Remove screw and remove console ashtray bracket.
8. Remove screws and remove cup holder assembly.
9. Remove auxiliary input jacks and socket knob, cigarette lighter case.
10. Remove console sub harness.

Assembly

Assemble in the reverse order of disassembly.